

PROAIM

Spin-3 (3-Axis) Motorized Pan Tilt Head (PT-SPIN-3)

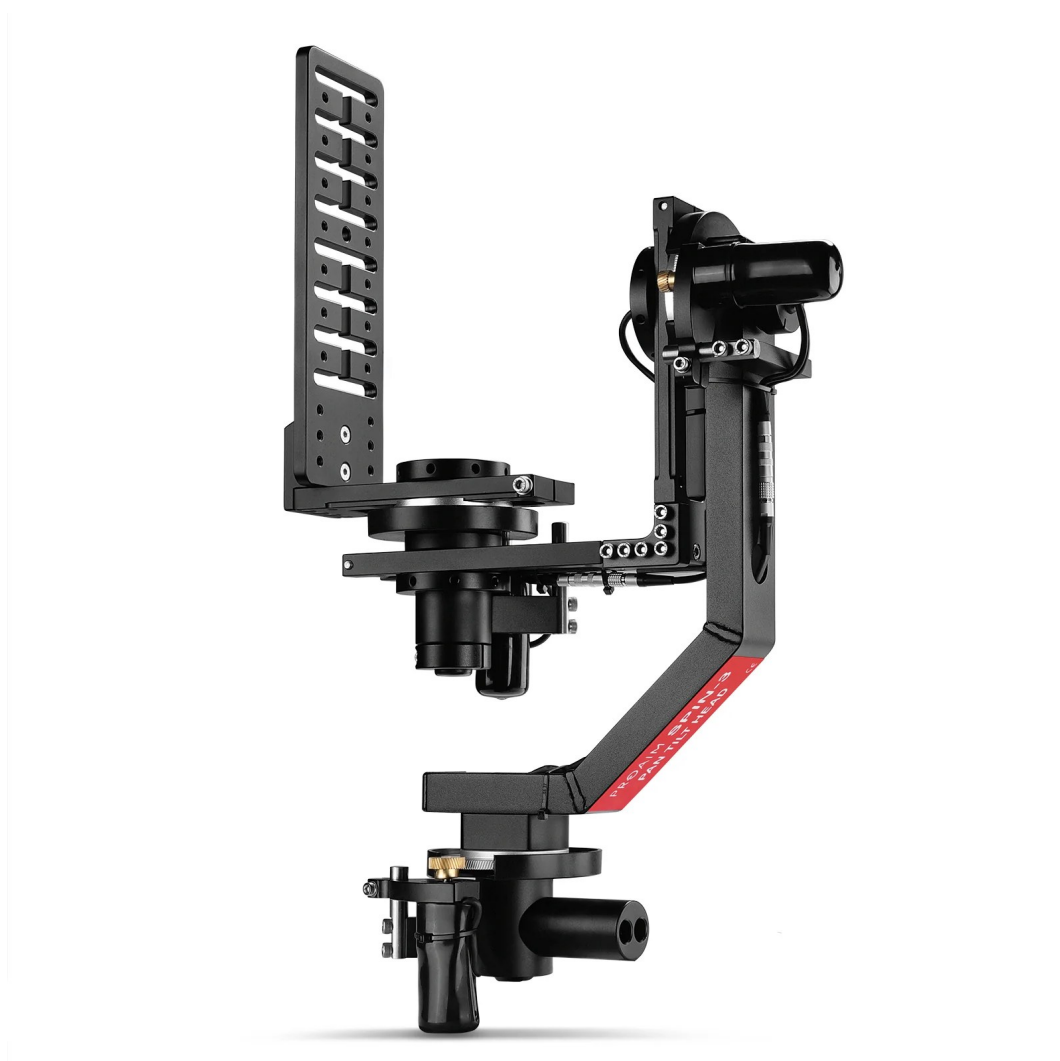

All rights reserved.

No part of this document may be reproduced, stored in a retrieval system, or transmitted by any form or by any means, electronic, mechanical, photo-copying, recording, or otherwise, except as may be expressly permitted by the applicable copyright statutes or in writing by the Publisher.

What's In The Box

Please inspect the contents of your shipped package to ensure you have received everything that is listed below.



All rights reserved.

No part of this document may be reproduced, stored in a retrieval system, or transmitted by any form or by any means, electronic, mechanical, photo-copying, recording, or otherwise, except as may be expressly permitted by the applicable copyright statutes or in writing by the Publisher.

INDEX

Sr. No	Particulars	Page No.
1	Spin-3 pan-Tilt head Setup	4
2	Mounting the Spin-3 Pan-Tilt Head	4
3	Installing Motors (Pan, Tilt, Roll)	4-5
4	Spin-3 Axis Pan-tilt Head Balancing Setup	5
5	Camera Mounting	6 - 7
6	Cable & XLR Cable Assembly	7 - 8
7	Parts of Spin-3 X Joystick Controller	9
8	AC Adapter & Universal Adapter Assembly	10
9	Balancing	10 - 12
10	2-Axis Possibility	13
11	Final Setup	14

Spin-3 pan-Tilt head Setup

Mounting the Spin-3 Pan-Tilt Head

- Attach the Pan-tilt mounting plate onto the Jib (**Not Included**) arm using the provided fasteners.
- Mount the Spin-3 Pan-Tilt Head on the plate and insert the knob.



Installing Motors (Pan, Tilt, Roll)

Note: Always mount motors before connecting to the gear to ensure proper balance.

- Slide the pan motor upward and tighten the screw with the 4mm Allen key.
Note: Mount the motor first without connecting it to the gear. Attach the motor to the gear only after the weight balance is correctly set.

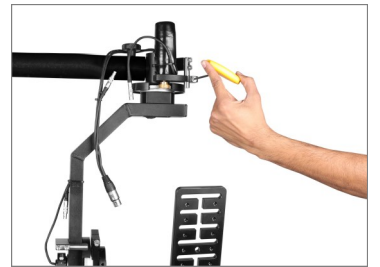

- Connect the LEMO connector wire.



- Attach the tilt motor to the tilt axis on the pan-tilt head.
Note: Do not connect the gear until the weight balance is correct.

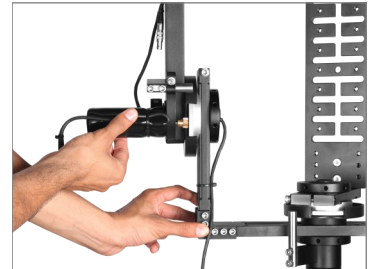
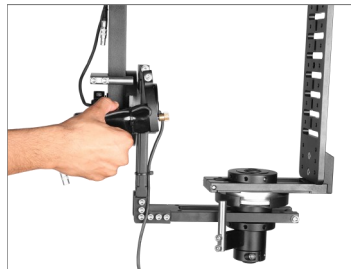

- Tighten with the help of a 4mm Allen key.

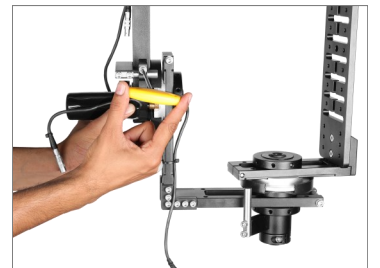

- Attach the LEMO connector of the tilt motor.

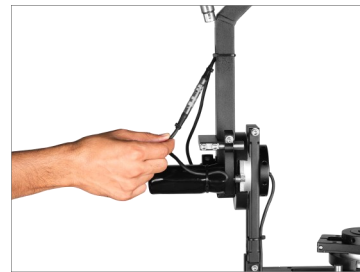

- Attach the roll motor to the roll axis on the pan-tilt head.

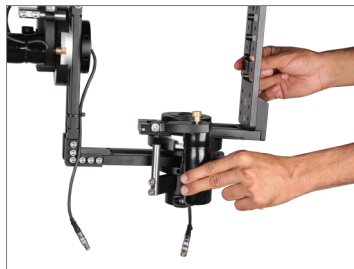

- Tighten using the 4mm Allen key and attach the LEMO connector.



- The setup is now ready for balancing, with all motors properly and securely attached.



Spin-3 Axis Pan-tilt Head Balancing Setup

- Loosen the tilt motor bolt with a 4mm Allen key to detach the motor gear.

Note: Always detach the motor gear before adjusting the pan-tilt arm.

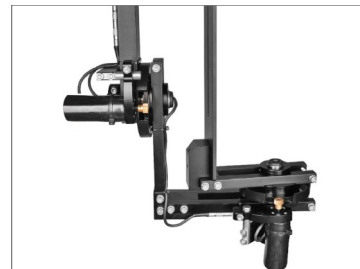

- Loosen the roll motor bolt with a 4mm Allen key. Detach the motor gear and rotate the camera mounting plate to balance.

Note: Ensure you detach the motor gear before balancing the head.



Camera Mounting

- Mount the Camera (**Not Included**) on the camera plate and secure it with the mounting bolt.

Note: Slide the camera forward or backward on the plate to achieve proper balance.



- Tighten the bolt using a screwdriver or 3/16" Allen key (**Not included**).



- Use a 4mm Allen key to loosen the check nut, then adjust the sliding balance arm with a 3/16" Allen key (**Not Included**) to properly balance the Roll Axis using the sliding arm and counterweight.



- After balancing the roll axis, tighten the check nut and the sliding balancing arm.



- loosen the tilt sliding balancing arm or check nut.



- Balance the tilt axis using the sliding balance arm.
- Manually tilt the camera side to side to achieve proper balance.

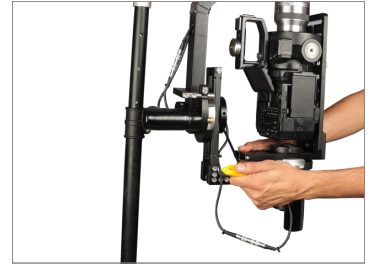
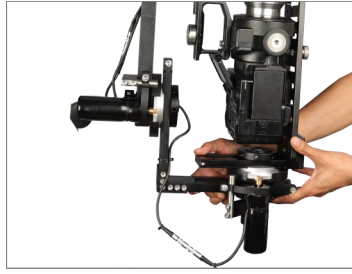

- Once balanced, tighten the check nut and sliding balancing arm.



- After balancing the tilt axis, attach the tilt motor to the tilt gear and tighten the bolt using a 4mm Allen key.

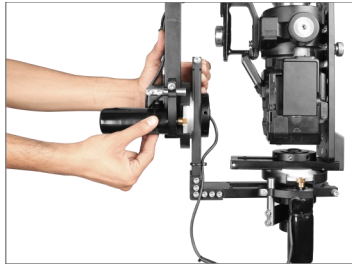

- After balancing the roll axis, attach the roll motor to the roll gear and tighten the bolt with a 4mm Allen key.

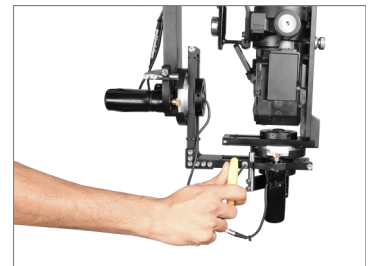
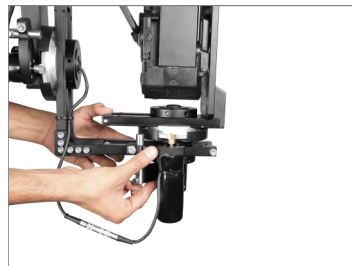

- After balancing the pan axis, attach the pan motor to the pan gear and tighten the bolt with a 4mm Allen key.



Cable & XLR Cable Assembly

- Connect the female end of the Pan-Tilt cable to the male end of the XLR cable.



- Connect the cable's female end to the Joystick controller.



- Connect the AC Adapter's female end to the Joystick controller.



- **Speed Controller** :- Adjusts the speed of pan, tilt & Dutch roll based on your shot's requirements.
- **Dead Spot Control** :- The Dead spot control determines the center band of the joystick where no motion will occur and ensure no crossover to the other axis when not wanted. you can adjust your joystick when it is not center by rotating this knob clockwise. If You observe the head moving without deflecting the joystick, it will be necessary to adjust center ring.
- **Damping Control** :- Damping control knob prevent the Head from stopping abruptly With a jerk, giving you smooth endings. The amount of damping is increased by rotating the damping knob clockwise.
- **Pan-Tilt Roll Direction** :- Allows reversing of the panning and tilting direction as needed.



Parts of Spin-3 X Joystick Controller

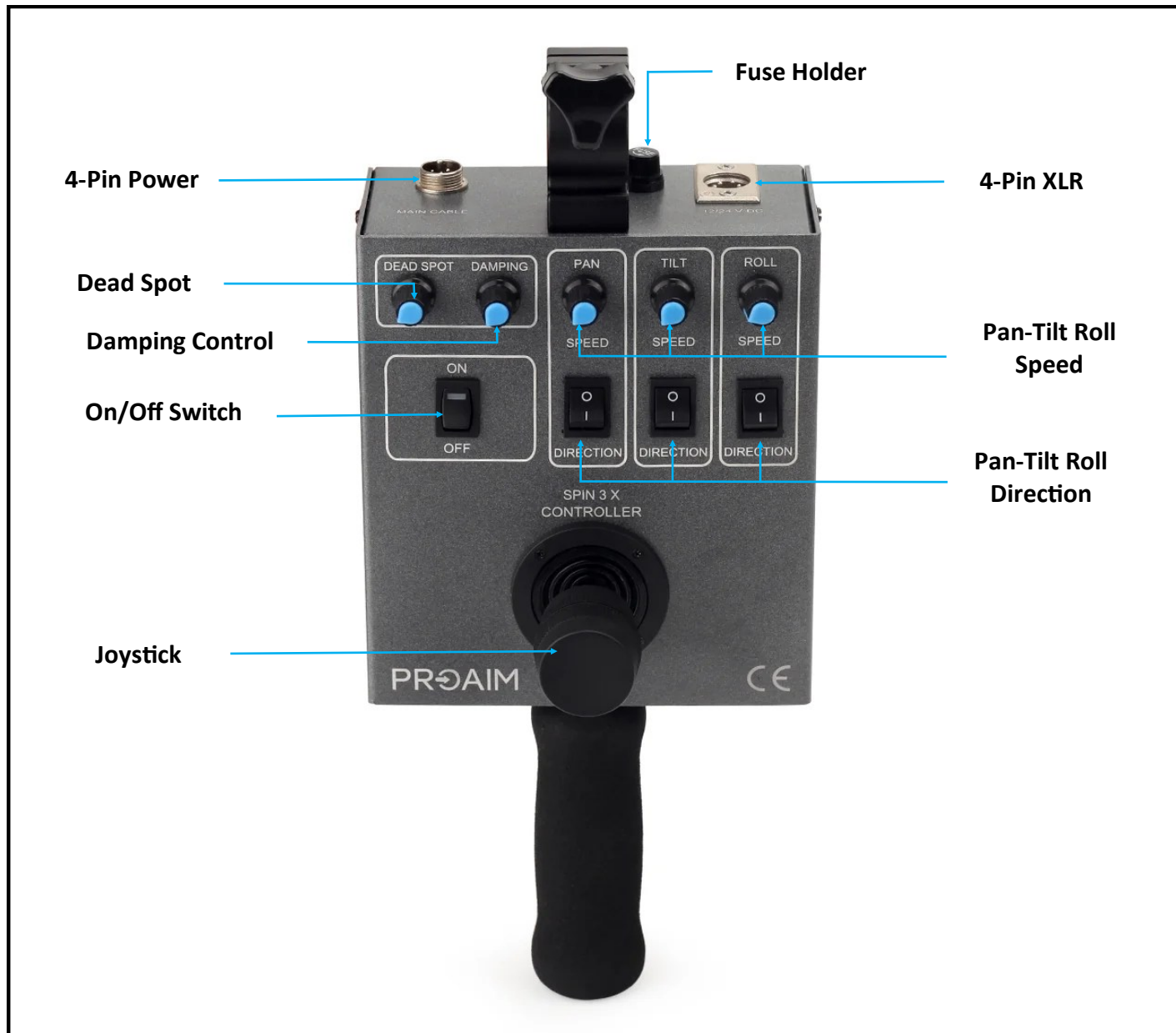

AC Adapter & Universal Adapter Assembly

CAUTION: Do not use an unregulated power supply.

- A regulated power supply must produce less than 24 volts.
- We do not recommend using 24 volts.
- More than 24 volts may cause permanent damage.

- Attach one end of the power cable to the adapter.



- Attach the Power cable's other end to the Universal adapter.



Balancing

When you're balancing a camera on a motorized 3-axis pan-tilt head with a camera, it's often necessary to disengage the motors to ensure a precise balance without any motor resistance. Follow these steps to balance the setup:

1. Disengage Motors: Turn off or disengage the motors of the pan-tilt head system. This ensures that no external force (from the motors) interferes with the balance process. **Disengaging the motors** on the pan-tilt head using a screw (without removing the motor entirely), the idea is to temporarily allow the head to move freely for manual balance adjustments. This screw allows the motor to disengage from actively controlling the axis but keeps it physically attached.

2. Mount the Camera: Securely attach the camera to the mounting plate of the pan-tilt head. Ensure that the camera is tightened properly to avoid any unwanted movements during balancing. Ensure the camera is firmly attached but can still slide on the plate for further adjustments. You may need to **slide the camera forward or backward** on the plate slightly to help achieve the perfect balance, especially if using long lenses or heavy camera setups.

3. Adjust the Sliding Balance Arm: Move the camera forward or backward along this arm to adjust the centre of gravity. The goal is to have the camera remain stable in a horizontal position without tilting forward or backward. **For front-heavy setups:** Slide the axis arm backward to distribute the weight more evenly across the head. **For rear-heavy setups:** Slide the axis arm forward to balance the load. This sliding arm helps compensate for the additional weight and allows more precise balancing, reducing the need for motor strain.

4. Fine-Tune Balance Using Counterweights:

Attach an appropriate **counterweight** (or set of counterweights) on the opposite side of the imbalance:

If the camera is **front-heavy** (tipping forward), place a counterweight on the back of the rig.

If the camera is **back-heavy** (tipping backward), place a counterweight in the front.

For **side-heavy** imbalances (e.g., due to a heavy accessory like a monitor on one side), add the weight on the opposite side.

This process ensures the camera is finely balanced, reducing motor load and improving the overall performance of your pan-tilt head, especially for heavier setups.

5. Balance the Tilt Axis (With the help of sliding balance arm and counterweight)

Tilt the camera up and down manually to check its balance on the tilt axis.

If the camera tilts forward: Slide the camera backward on the plate.

If the camera tilts backward: Slide the camera forward.

Keep adjusting until the camera remains still at any tilt angle. This shows that the COG is aligned with the tilt axis.

6. Balance the Roll Axis (With the help of sliding balance arm and counterweight)

Tilt the camera side-to-side manually to balance the roll axis.

If the camera tilts to one side: Adjust the sliding axis arm horizontally to the opposite side to counterbalance the weight.

For extremely off-balance setups, additional **counterweights** or accessories (like a monitor or battery) might be needed on the opposite side to achieve a stable balance.

Adjust until the camera stays level without tilting to either side.

7. Balance the Pan Axis (Horizontal Rotation)

Unlock the pan axis and rotate the head manually.

The camera should **stay level** and not drift to one side as it rotates.

If the camera drifts or leans, adjust the **camera plate** position slightly left or right or fine-tune the sliding axis arm to adjust the balance.

8. Recheck Balance in All Axes

Once the camera is adjusted on the tilt, pan, and roll axes, recheck each axis by manually moving the camera:

Tilt the camera up and down: The camera should stay in place without falling forward or backward.

Roll the camera left and right: The camera should stay level and not tilt to either side.

Pan the camera left and right: The camera should not drift or wobble as it rotates.

If the camera moves or wobbles in any direction, go back to the sliding axis arm, counterbalance weights, or mounting plate adjustments.

Note: - Proper **balancing** of the camera setup can significantly reduce **gear backlash** in motorized pan-tilt heads.

9.Re-engage the Motors: After confirming the camera is balanced, turn the motors back on to power the system. The motors should now require minimal effort to maintain the camera's position, leading to smoother and more efficient operation.

10. Lock and Secure All Adjustments

Once the camera is fully balanced, tighten all locks and screws to secure the setup. Ensure the **sliding axis arm is locked** in place and any counterweights or accessories are securely mounted.

11. Power On and Test the System

After securing the balance, power on the pan-tilt head and run test movements through the **full range of motion**:

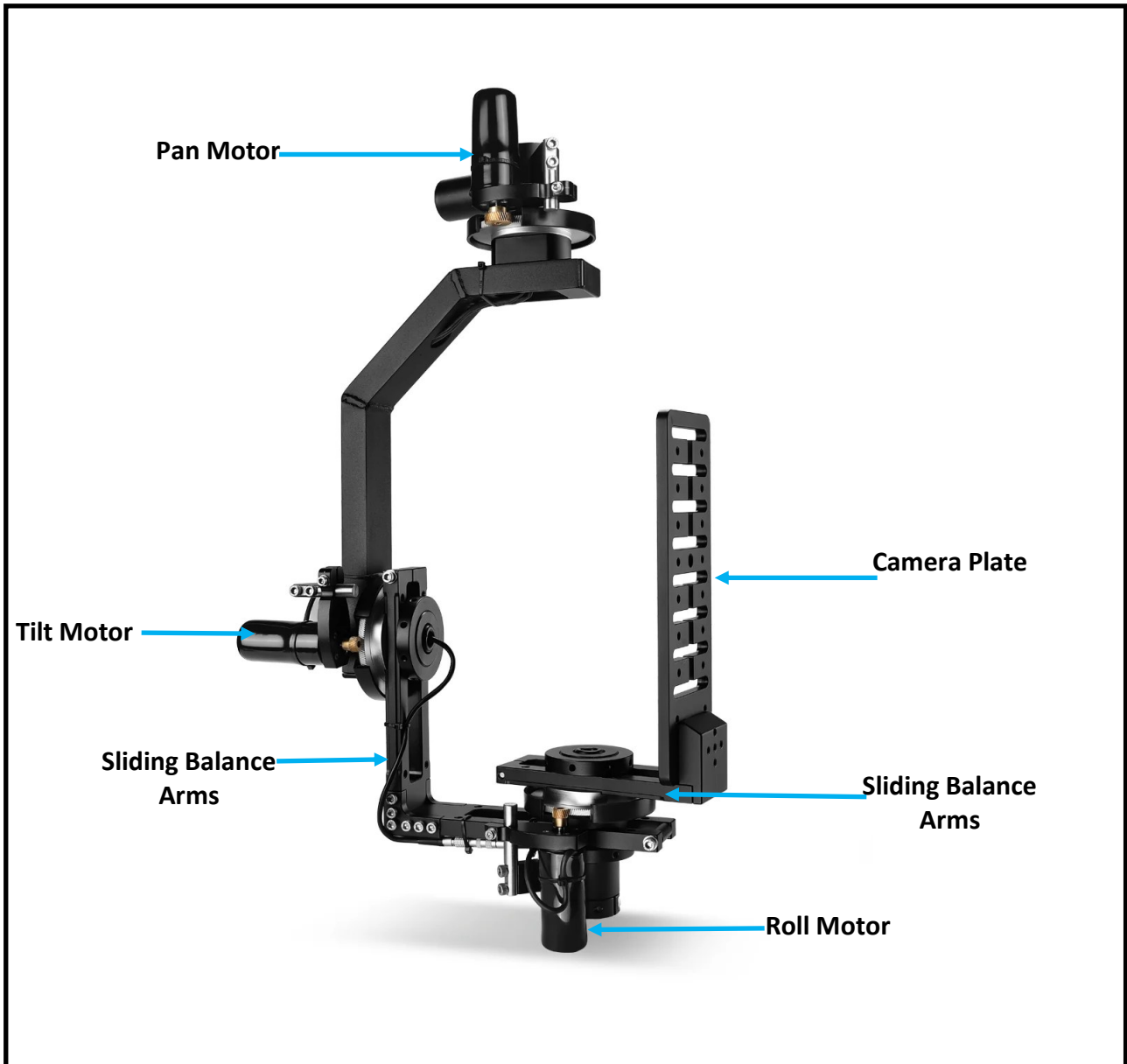

2-Axis Possibility



**YOUR PROAIM SPIN-3 MOTORIZED PAN-TILT HEAD
ALL DRESSED UP AND READY TO GO!**



(SHOWN WITH OPTIONAL ACCESSORIES)

Warranty: We offer a one-year warranty on our products from the date of purchase. During this period, we will repair the product free of charge for labor or parts. The warranty does not cover transportation costs or products that have been misused or accidentally damaged. All warranty repairs are subject to inspection and evaluation by our team.

Liability: We are not liable for any damage caused by third-party products, mishandling during transit, accidents, misuse, neglect, or unauthorized servicing of the product.

Contact Us: In case of any dissatisfaction, please contact us immediately. We are committed to providing the utmost support and care to ensure your satisfaction with our product.