

Assembly Manual



What's In The Box

Please inspect the contents of your shipped package to ensure you have received everything that is listed below.



Boxer HD-2X Motorized Pan Tilt Head



Pan and Tilt Motor



Focus & Zoom Controller



Joystick Controller



Focus and Iris Motor



Controller with Battery Box



Head Connector



43ft Long Cable

All rights reserved.

No part of this document may be reproduced, stored in a retrieval system, or transmitted by any form or by any means, electronic, mechanical, photo-copying, recording, or otherwise, except as may be expressly permitted by the applicable copyright statutes or in writing by the Publisher.



12ft Long Cable



5m AC Power Cable



3 x Knobs



Ratchet Knob



Extra Motor Gears



Belt



3 x Allen Keys
(Size: 2mm, 3/16", 6mm)



Universal Adapter



MS Check Nut
(Size : 1/4")



4x Wing Nuts



Rod For Motor Holding



Bag Packing

INDEX

Sr. No	Particulars	Page No.
1	Boxer HD-2X Motorized Pan Tilt Head Mounting	4
2	Pan Tilt Motor Mounting	4
3	360° Pan Rotation	5
4	360° Tilt Rotation	6
5	Camera Mounting	6
6	Camera Balancing	7-8
7	Lens Bracket Mounting	8
8	Rod Mounting	8
9	Iris Motor Mounting	8-9
10	Focus Motor Mounting	9
11	Controller Box Mounting	9
12	Focus Zoom Controller Mounting	9
13	Joystick Controller Mounting	10
14	Battery Mounting	10
15	Cables Mounting	10-12
16	Focus Zoom Controller	13
17	Focus Control /Follow Focus System	13
18	Joystick Controller	14
19	Speed, Damping, Iris & Direction Control	14
20	Controller Box Mounting	15
21	PAN & TILT Motors	15
22	Focus And Iris Mount	16-17
23	Focus Servo	18
24	Follow Focus System	19
25	Joystick Handle	20
26	How To Eliminate Zoom Creeping	20
27	Electrical Cable Routing	21-22
28	Electronic Controls	23-24
29	Final Setup	24

Boxer HD-2X Motorized Pan Tilt Head Setup

Boxer HD-2X Motorized Pan Tilt Head Mounting

- Insert the Boxer Pan Tilt head into the Jib's connector.
- Then insert the knob and tighten it.



- Now, insert the Ratchet knob and lock it securely.



Pan Tilt Motor Mounting

- Attach the Pan Motor on the top of the Boxer Head via the pin and carefully align the gear.

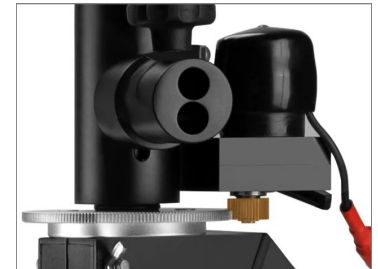

- After attaching the motor, tighten the knob to secure it.



- Tilt motor to the bottom of the Boxer Head via the pin and tighten it using the knob.

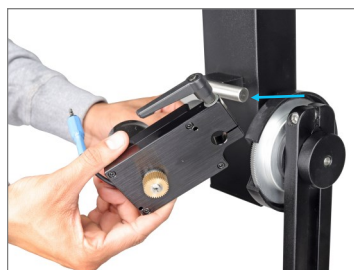

360° Pan Rotation



360° Tilt Rotation



Camera Mounting

- Mount the camera (**Not Included**) onto the mounting plate.

NOTE: Tilt motor gear & Boxer head's tilt gear are detached before mounting the camera.



- Insert the knob to the bottom and tighten it.



Camera Balancing

- Now, loosen the thumb knob and then loosen the screw using a 3/16" Allen key.



- Slide the camera plate upward/downward and balance the camera.
- After balancing the Camera, re-tighten using the thumb knob and re-tighten the screw securely.



- The camera is securely balanced on the camera plate.

NOTE: Set the camera position and balance the camera per your requirement.



Camera Balancing In Different Ways



- After balancing the camera, carefully attach the Tilt motor gear with the Tilt head gear, and then tighten the knob.

NOTE: Ensure to align the gears only after securely balancing the camera.



NOTE: This system uses two coreless high-torque DC motors that provide inaudible and precise movements with zero backlashes and performance similar to top industry solutions at an affordable cost.

Lens Bracket Mounting

- Attach Lens Bracket to the camera and re-tighten the Lens bracket knob.

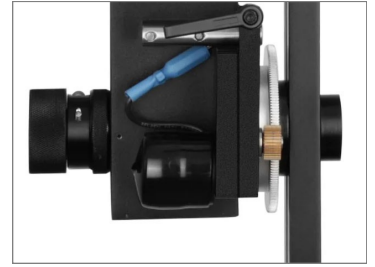

- The lens bracket is now securely attached to the camera.

NOTE: Our boxer head comes equipped with a convenient built-in lens control for Fuji/Canon ENG lenses. It is specially designed with an 8-pin zoom cable connector that is compatible with Canon and Fuji ENG lenses, featuring the same 8-pin connector.



Rod Mounting

- Slide the Rod into the Lens bracket and re-tighten the knob.



Iris Motor Mounting

- Slide the Iris motor into the Rod.
- Carefully, align the Iris motor gear with the Camera Iris gear.



- Re-tighten the knob after ensuring the gears alignment.



Focus Motor Mounting

- Slide the Focus motor into the Rod.
- Carefully align the Focus motor gear with the Camera Focus gear.
- Re-tighten the knob after ensuring the gears align.
- Both motors are securely attached to the camera.



Controller Box Mounting

- Insert the knob into the Jib's mounting head.
- Then insert the controller box onto the knob and tighten it.



Focus Zoom Controller Mounting

- Slide the Focus Zoom controller on the weight Rod (Right side) and tighten the knob.



Joystick Controller Mounting

- Slide the Joystick Box on the Weight Rod (Left side) and tighten the knob.



Battery Mounting

- Mount the Battery (Not Included) on the Controller Box battery plate.
- Similarly, mount the second battery.



Cables Mounting

- Connect one end of the 43ft long cable with the Controller box(20 Pin).



- Insert the other end of the 43ft long cable into the jib and pass it from the Jib Head's top hole.

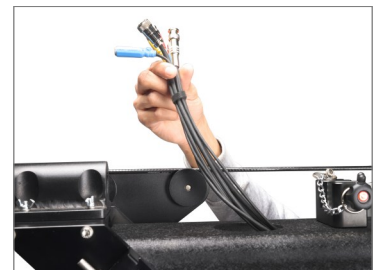

- Connect one end of the 12ft long cable with the Controller box (13 Pin).



- Connect one end of the AC Power cable to the Controller box (3 Pin).

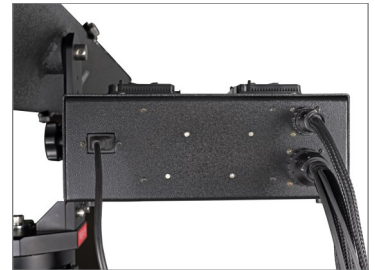

- Connect the second end of the Power cable to the adapter.



- Connect the **Red** Cable (4 Pin) of the 43ft long cable with the Iris motor.



- Connect the **Blue** Cable (4 Pin) of the 43ft long cable with the Focus motor.

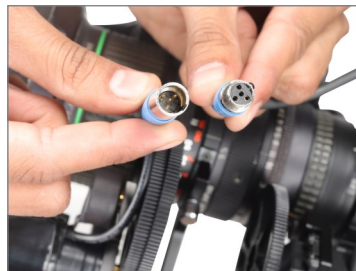

- Connect the **Blue** Cable (1 Pin) of the 43ft long cable with the Tilt motor.



- Connect the **Red** Cable (1 Pin) of the 43ft long cable with the Pan motor.

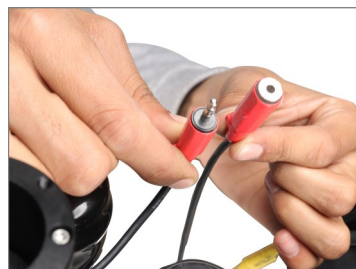

- Connect the BNC cable to the Camera's Video out connector.



- Connect the 8-pin connector of the 43ft long cable to the Camera's 8-pin connector.



- Connect one end (7 Pin) of the 12ft cable to the Joystick Controller.

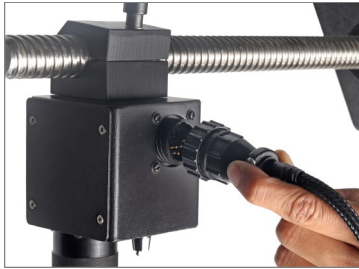

- Connect the other end (8 Pin) of the 12ft cable to the Zoom Controller.



- Press the ON button to turn on the Controller Box.



- Now, the Camera is securely mounted on the Boxer head.



Focus Zoom Controller

- 1. Zoom On/Off:** works as a zoom speed controller; when switched OFF, the zoom speed is at its maximum, and when switched ON, the zoom speed can be controlled via the 'zoom rate' knob.
- 2. Zoom Rate:** When the 'zoom on/off' button is on, the knob allows you to control the zoom speed.
- 3. Zoom Direction:** The button reverses the current zoom direction from zooming in to zooming out or vice-versa.
- 4. See-Saw Button:** The rocker pot facilitates forward and reverse zoom direction.



Focus Control /Follow Focus System

- 1. Focus Rate:** It is a ramping control that controls the elapsed time to perform the focus.
- 2. Focus Travel:** Sets the distance the focus servo will rotate and prevents the servo from hitting the lens stops.
- 3. Focus Direction:** The button reverses the focus direction from left to right or vice versa.
- 4. Focus Control Knob:** Rotates the servo motor as per your requirement.
- 5. Focus On/Off Switch:** Turning ON this switch will allow you to control the focus movement via the given control points, whereas turning OFF this switch will completely turn off the focus functions.



Joystick Controller

- The Joystick Zoom Controller enables the operator to increase the magnification, empowering them to easily take well-framed shots.
- The Joystick focus controller lets the operator make precise adjustments to achieve the ideal sharpness and clarity.



Speed, Damping, Iris & Direction Control

The main control box of our pan-tilt features a 2-V-mount battery plate, which facilitates the convenient mounting of V-mount batteries. These batteries offer a significantly larger capacity, thereby enabling prolonged uninterrupted operation.

Speed Control: It features two independent speed controller switches that let you control and precisely adjust the speed, suiting the requirement of the shot.

Damping Control: Two independent Damping control switches prevent the Head from stopping abruptly with a jerk, giving you smooth endings.

Pan-Tilt Direction: There are also two independent switches, so you can easily change and reverse the direction of panning & tilting as and when required.

Iris : With the Iris control switch, you can adjust the camera's aperture to accommodate prevailing day/night light conditions, improving visual clarity.

Moreover, the controller box is equipped with an up/down flip knob, which must be switched when using Fuji or Canon lenses.



Controller Box Mounting

- Insert the knob into the Jib's mounting head.
- Then insert the controller box onto the knob and tighten it.

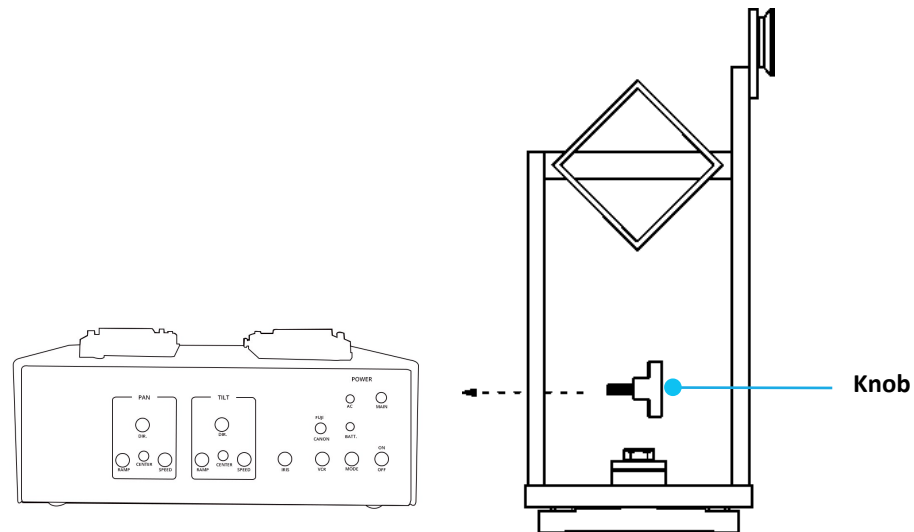

PAN & TILT MOTORS

- The Pan and Tilt Motors are mounted to the Head using a knob and a pinch type motor mount bracket.
- Engage the motors by rotating them and tightening the knob.



Focus And Iris Mount

- The Focus/Iris assembly consists of two servos with gear wheels attached.
- This assembly mounts to the screw hole utilized by the lens manufacturer to mount their cable drive focus systems.
- As you tighten the Lens Mount Knob to mount the assembly, you must be careful that the screw does not bottom out inside the lens.
- If you continue to force the screw you may do internal damage to your lens.

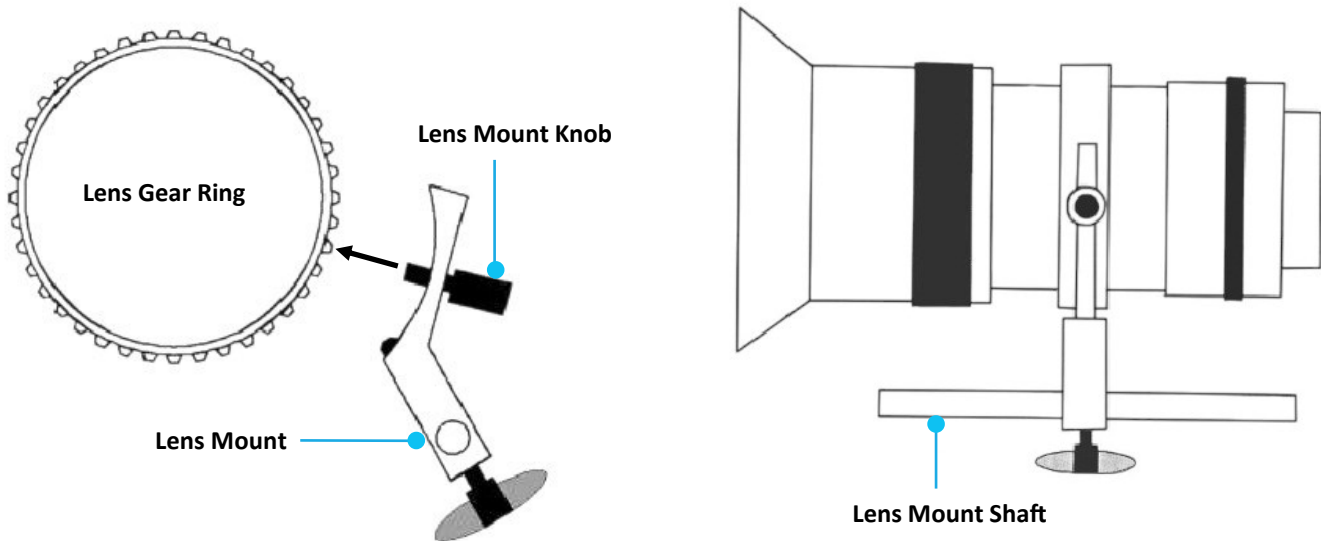

- Occasionally, the curvature of this mount is greater than the lens curvature.
- This means there will be contact only at the center of the mount instead of along the entire curve.
- This can cause the Focus/Iris assembly to twist on the lens.
- To correct this problem, adjust the set screw in the Lens Mount.
- Back out this set screw only far enough to touch the lens.

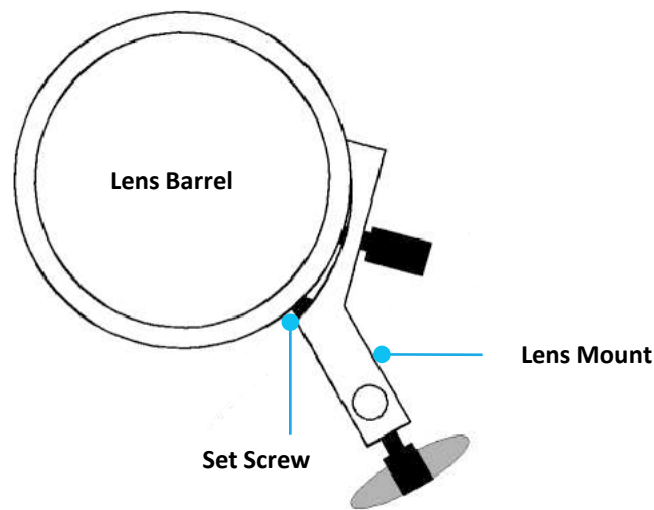

IRIS SERVO

1. The lens auto iris switch should be in the off position.
2. Slide the Iris Servo onto the Lens Mount Shaft, plug the servo into the blue connector, and turn the unit on.
3. Rotate the Lens Iris clockwise (iris closed) until you hit the lens stop. Rotate the Iris Servo gear (using the Iris Knob on the control box) counterclockwise until you hit the servo stop. This will synchronize the Lens and the Servo stops.
4. Engage the Iris Servo with the Lens by rotating it on the Lens Mount Shaft. Lenses with extenders may require the Iris Servo to be reserved in its mount.

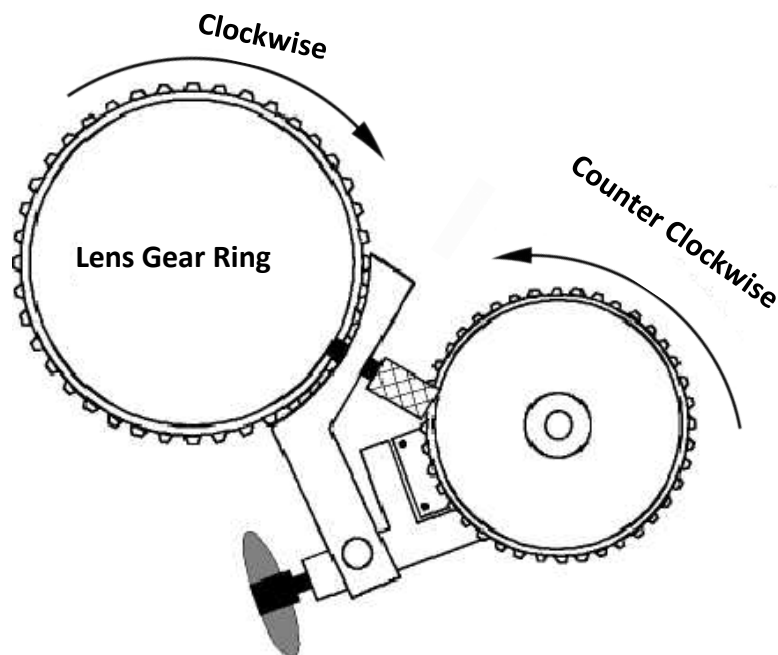
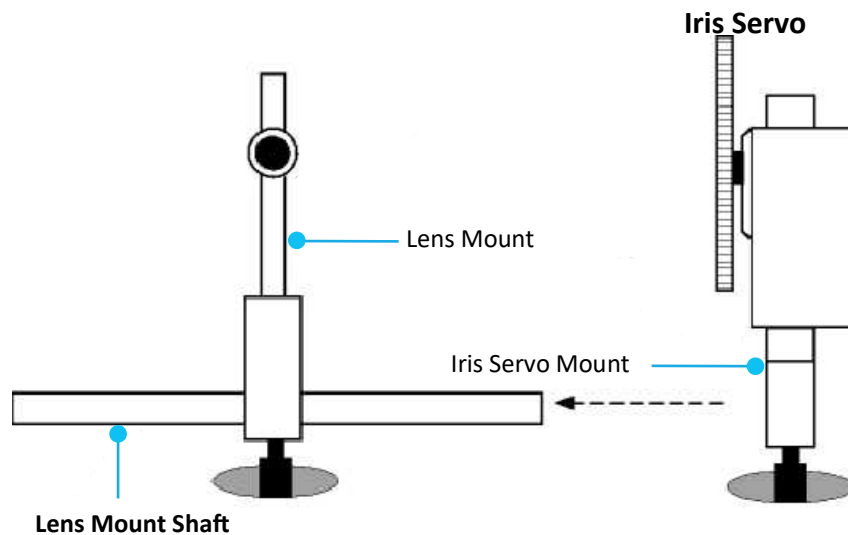

- If you have a Canon Lens, the Master Gear will directly engage the lens.
- If you have another lens, you will need to add extra gear.
- Slip the extra gear over the hub of the Master Gear and secure it with the 4-40 screw.

Focus Servo

1. Slide the Focus Servo onto the Lens Mount Shaft and plug it into the red connector.
2. Rotate the Servo on the Shaft until the Lens Focus Gear ring and servo gear engage.
3. The Focus Servo Bracket is spring-loaded. Compress this spring slightly when you engage the gears.

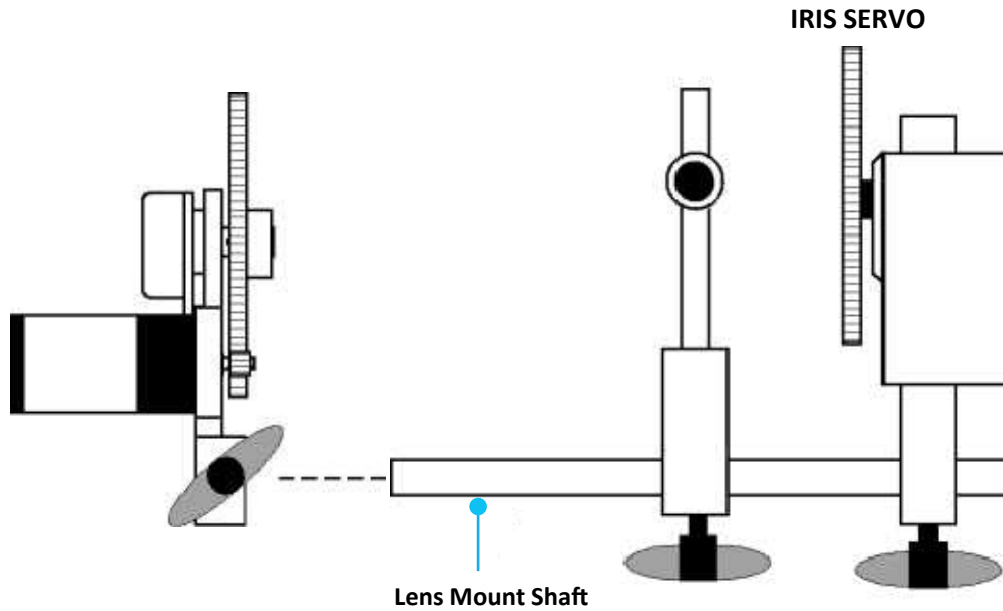

Rotate Servo Bracket to engage servo gear and lens.

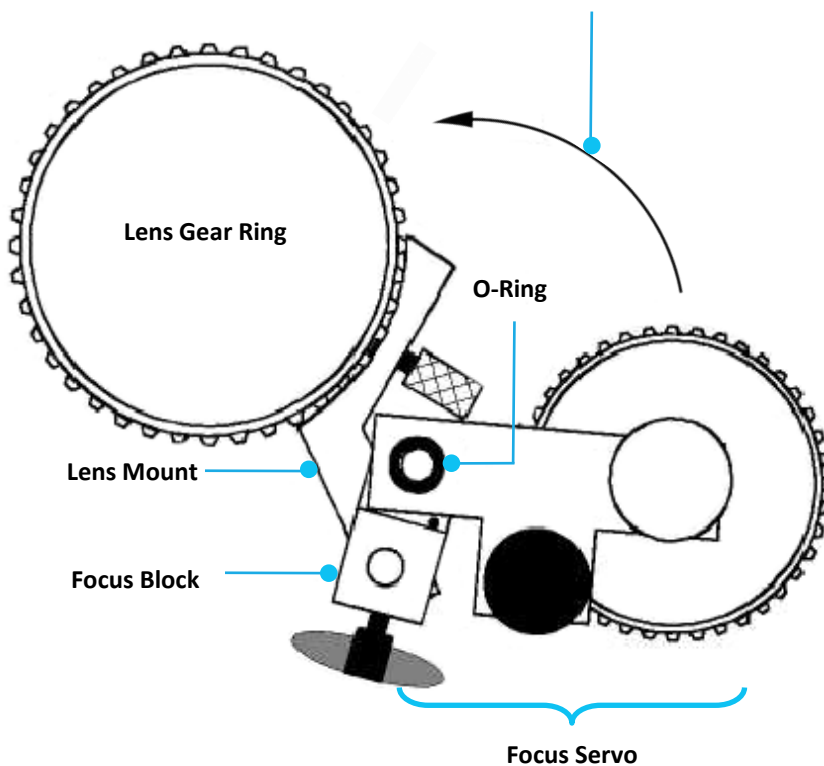

Follow Focus System

1. **Zoom Rate:** When the 'zoom on/off' button is on, the knob allows you to control the zoom speed as per your requirement.
2. **Rate Switch:** Disconnect the Zoom rate for full speed Zoom operation.
3. **Zoom:** The zoom is controlled in the usual way with a rocker on top.
4. **Zoom Direction:** The button reverses the current zoom direction from zooming into zooming out or vice-versa.
5. **Focus On/Off Switch:** Turning ON this switch will allow you to control the focus movement via the given control points, whereas turning OFF this switch will completely turn off the focus functions.
6. **Focus Rate:** It is a ramping control that controls the elapsed time to perform the focus.
7. **Focus Travel:** Sets the distance the focus servo will rotate and prevents the servo from hitting the lens stops.
8. **Focus Direction:** The button reverses the focus direction from left to right or vice versa.
9. **Focus Control Knob:** Rotates the servo motor as per your requirement.

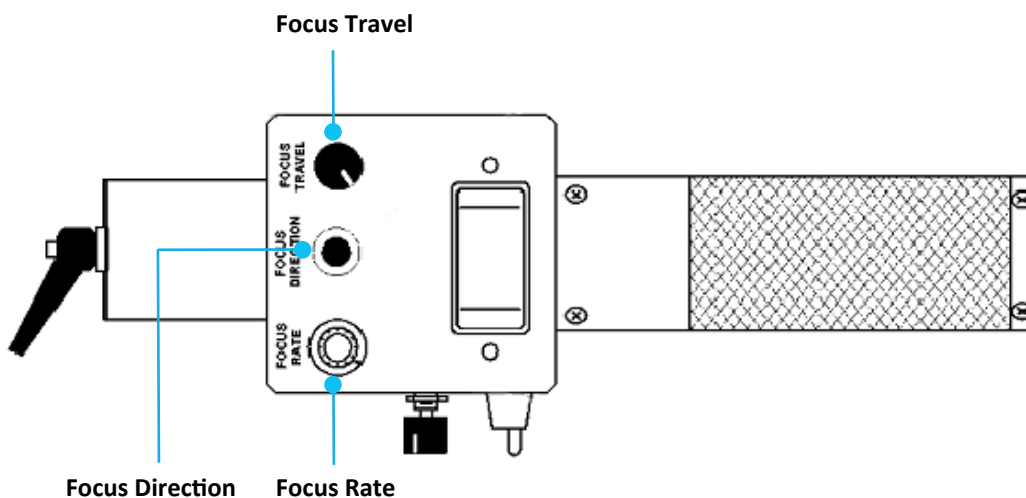
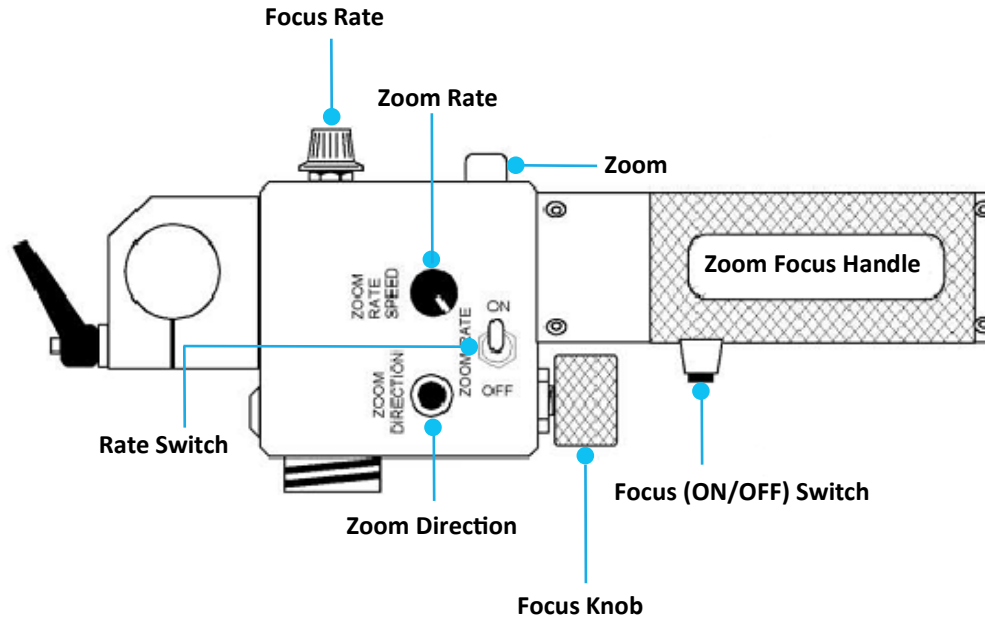

Joystick Handle

- The joystick is a two-axis variable-speed servo controller designed to control the panning (horizontal movement) and tilting (vertical movement) of a camera or device in a pan-tilt system.

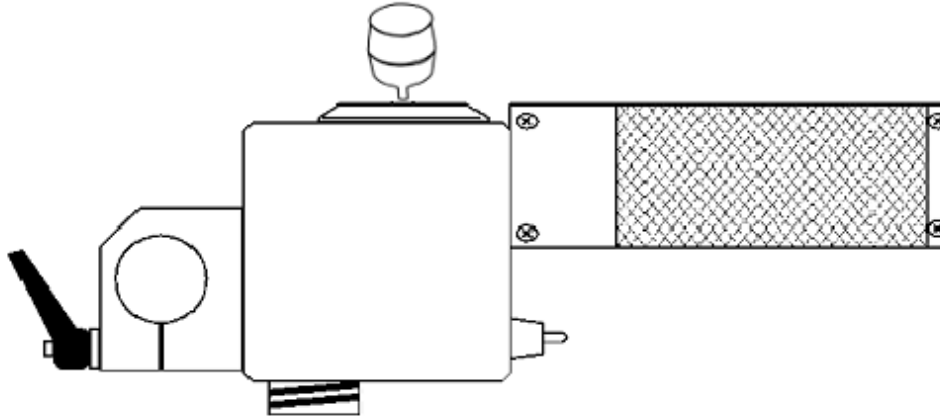

How To Eliminate Zoom Creeping

Two possible situations can cause a creeping zoom problem: The lens switch on the back of the control box being in the wrong position and natural variations from lens to lens.

- Lens-to-lens variation can be corrected by adjusting a trim pot inside the Zoom Handle.
- The lens switch must be positioned correctly before the trim pot is adjusted.

Please follow the instructions below to ensure proper setup.

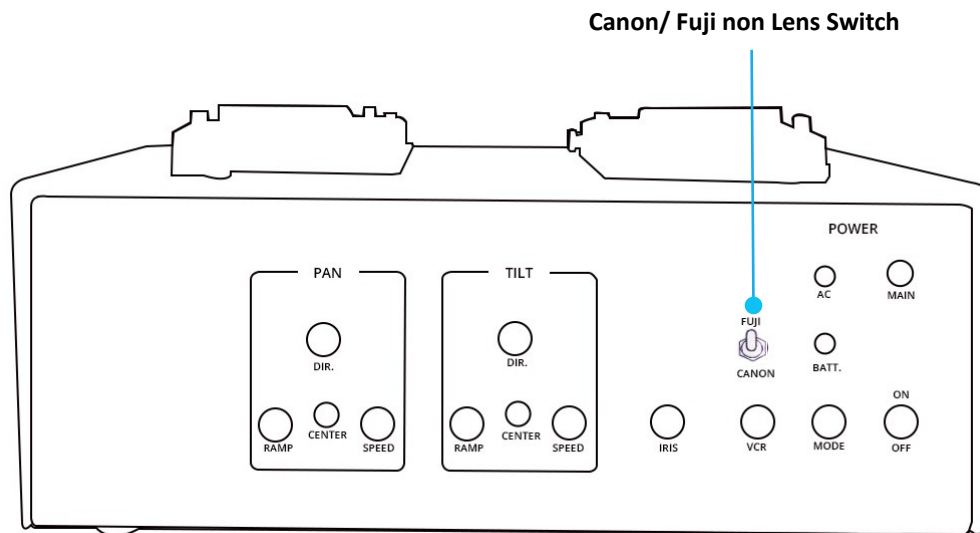

Lens Switch

1. Turn the camera on and observe how the lens responds. Rotate the Zoom Rate from minimum to maximum. If you can zoom the lens in and out using the Zoom Rate control, the lens switch is in the wrong position.
2. Once the lens switch is in the correct position, the lens should work generally except for the creeping.

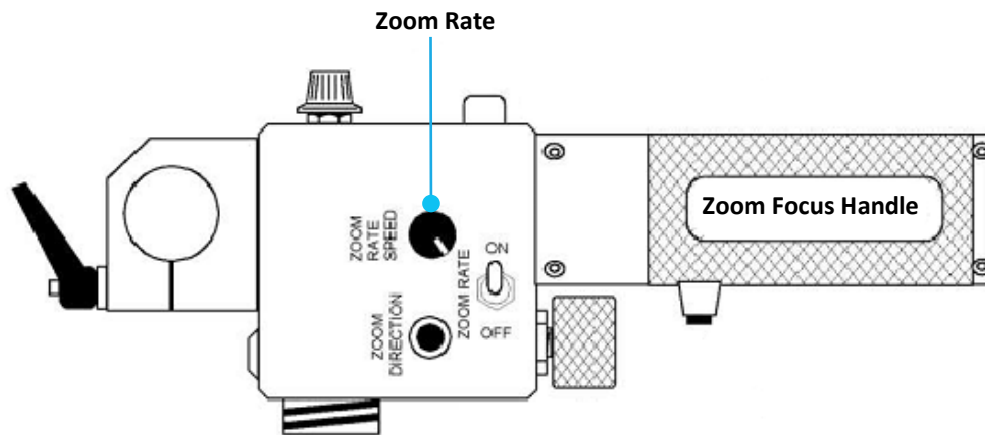

Electrical Cable Routing

Head Cable & Control Cable

Blue 4 Pin **Focus Motor**

Red 4 Pin **Iris Motor**

1. Run the Head Cable along the top of the jib tube and fasten it in place with the straps.
2. Connect the Focus Motor (blue) and the Iris Motor (red) using the 4 pin Switch craft connectors.
3. Form a slack loop between the Head and the Jib arm. To form the proper size loop, it may be necessary to slide the Head Cable along the jib tube.

Control Cable

1. Slide the weight bar into the Rear Boom Section. Attach the Joystick and Zoom/Focus Handle to the weight bar.
2. Plug the 16-pin Amp connector of the Control Cable into the Control Box and route it down the Rear Tube section toward the weight bar.

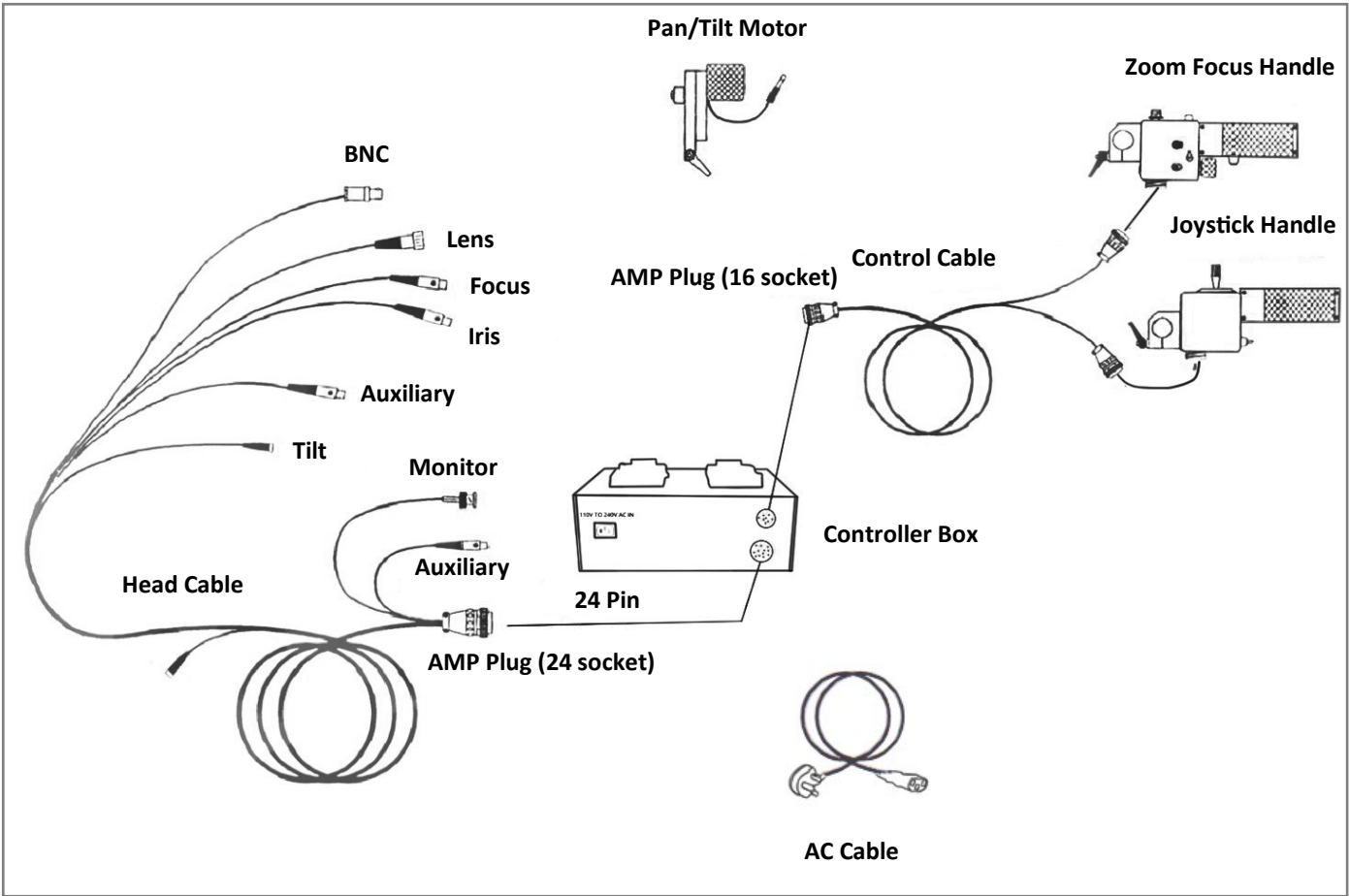

Controller Box

- The controller box of our pan-tilt system features a dual V-mount battery plate, allowing for the convenient attachment of V-mount batteries.
- This provides a significantly larger capacity, ensuring extended and uninterrupted operation.
- The high-performance head can be powered by either a 14.8 VDC battery (**Not Included**) pack or an included 110-240VAC adapter, ensuring optimal functionality.

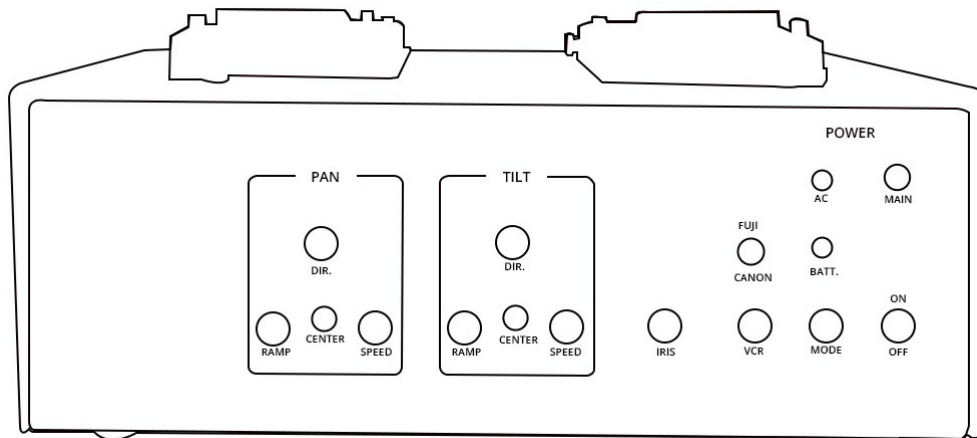

Front Side

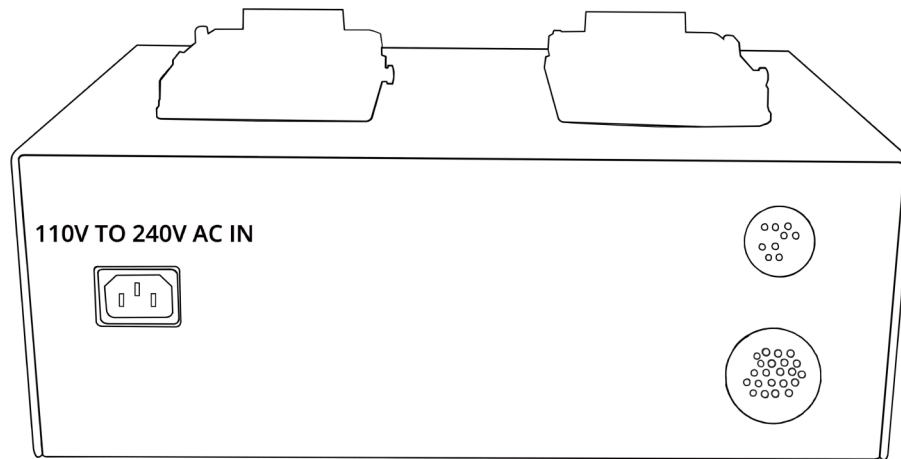

Back Side

Electronic Controls

RAMP: An adjustable acceleration ramp that cushions the start and stop of the pan and tilt motion. The amount of cushion is increased by rotating the "Ramp" knob clockwise.

CENTER: Sets the pan or tilt output voltage to zero. This is set at the factory and does not require operator adjustment under normal circumstances. If you observe the head moving without deflecting the joystick, it will be necessary to adjust centering.

- a. Disengage the motors from 4 in. gears.
- b. Adjust the RAMP to minimum and the SPEED to maximum.
- c. Position the head so that you can observe the motor pinion.
- d. Adjust the centering control until the gear stops moving.

SPEED: It features two independent speed controller switches that let you control and precisely adjust the speed, suiting the requirement of the shot.

IRIS: With the Iris control switch, you can adjust the camera's aperture to accommodate prevailing day/night light conditions, improving visual clarity.

Moreover, the controller box is equipped with an up/down flip knob, which must be switched when using Fuji or Canon lenses.

VCR: Starts and stops the VCR providing your lens connector allows for this. Make sure the VCR switch on your lens is in the off position. Since most newer cameras require a momentary contact this is the type of switch that we have provided. If your recorder requires a maintained switch you will have to start and stop the recorder at the camera.

LENS: By pushing this switch, you change to Canon or Fuji non. If your lens does not work properly, this switch will probably be in the wrong position.

POLARITY: This switch enables you to change the direction of the Joystick per your requirement. When you under-slung the head, you will need to change the pan direction.

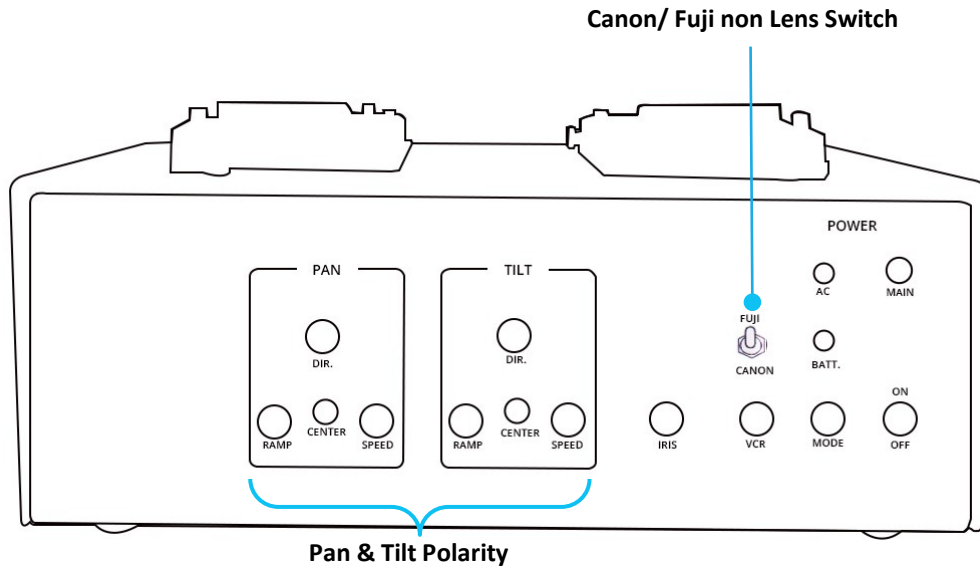

**YOUR PROAIM BOXER HD-2X MOTORIZED PAN/TILT HEAD
ALL DRESSED UP AND READY TO GO!**



(SHOWN WITH OPTIONAL ACCESSORIES)

Warranty: We offer a one-year warranty for our products from the date of purchase. Within this period, we will repair it without charge for labor or parts. The warranty doesn't cover transportation costs or a product subjected to misuse or accidental damage. Warranty repairs are subject to inspection and evaluation by us.

Liability: We are not liable for damage caused by products we do not supply or from mishandling in transit, accident, misuse, neglect, or lack of care of the product or service by anyone other than our company.

Contact Us: If you are dissatisfied, please get in touch with us immediately. We promise our utmost support and care until you use our product.